

# Large theater with 5,000 seats

## Purpose of installing AFC

1. Extending reverberation time for Reverberance
2. Increasing sound pressure level for Loudness
3. Exchanging the sound energy between stage and audience area for Uniformity
4. Improvement of Stage acoustics
5. Improvement of the sound field in Under balcony area

## System Configuration

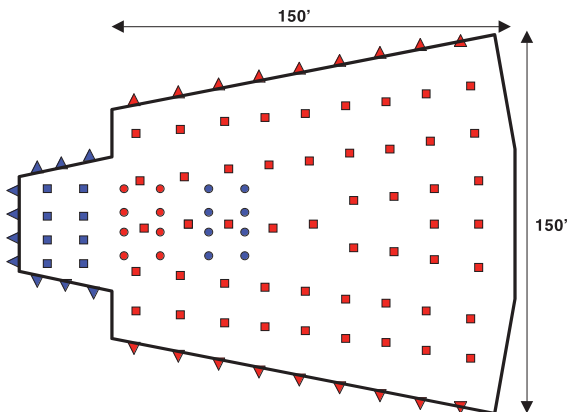

- : Microphone for reverberation
- : Loudspeaker for reverberation
- : Microphone for energy exchange
- : Loudspeaker for energy exchange

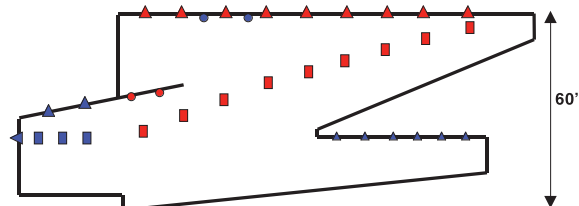
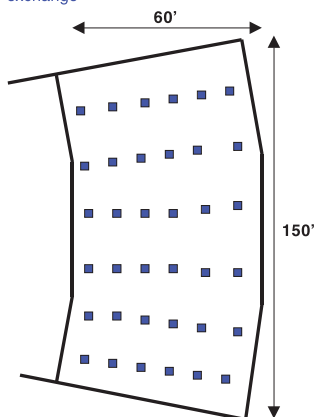

## System Diagram

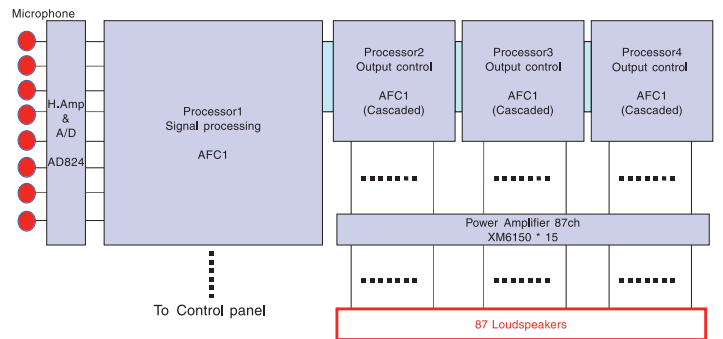

A reverberation control section

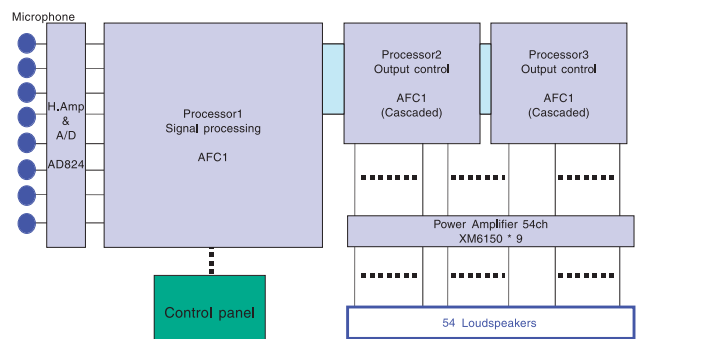

Control panel  
 Power ON/OFF  
 System ON/OFF  
 Sound field pattern A - F  
 Liveness 1-8

An energy exchange control section

## Large theater with 5,000 seats

## System components

No.	Description	Specification	Model	QTY
1	Microphone	e.g. Miniature Boundary-Layer Capsule Frequency range: 20 Hz - 20 kHz Sensitivity: 19 mV/Pa Equivalent noise level: A-weighted: 12 dB-A ,CCIR: 23 dB Signal-to-noise ratio (A-weighted): 82 dB-A Maximum SPL(0.5% THD): 128 dB	-	16
2	Head amp & AD	24-bit linear, 128-times oversampling Frequency response -3, +1dB, 20Hz-20 kHz, GAIN -62 dB Dynamic Range 110 dB Hum & Noise Level -92 dB	AD824	2
3	Sound field processing		AFC1	2
4	Output control section		AFC1	5
5	Digital I/O card		MY8-AE	4
6	Analog output card		MY8-DA96	18
	Power amplifier	Output level 100 W*6ch THD+N <0.2% S/N Ratio 100 dB Channel separation >60 dB	XM6150	24
7	Loudspeaker	e.g. Frequency Response 60Hz-16kHz Power Rating program/peak 60/200 Imp 6Ω SPL(1W,1m) 89 dB	-	54
8	Loudspeaker	e.g. Frequency Response 60Hz-16kHz Power Rating program/peak 300/600 Imp 8Ω SPL(1W,1m) 97dB	-	87
9	Control panel	Power ON/OFF System ON/OFF Sound field pattern 6 Liveness 1-8	Custom	1